



DESCRIPTION	PAGE
Motor top, Eliminator I	2
Motor top, Eliminator II	4
Container, Eliminator I	6
Container, Eliminator II	8
Wheels	10
Front nozzle, Eliminator II	12
Nozzles, tubes and hoses	14
Filters and dustbags	16
Wiring diagram	18

#### WHEN ORDERING PARTS

\* Use the digit numbers from the "Part. No." columns in this parts list.

\* Specify the serial number of the machine.

\* Use the space below to record the model and serial number for future reference.

Model \_\_\_\_\_ Serial no. \_\_\_\_\_

Model \_\_\_\_\_ Serial no. \_\_\_\_\_

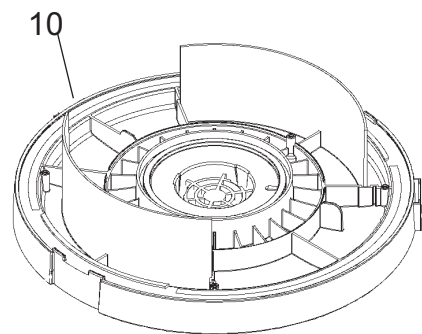
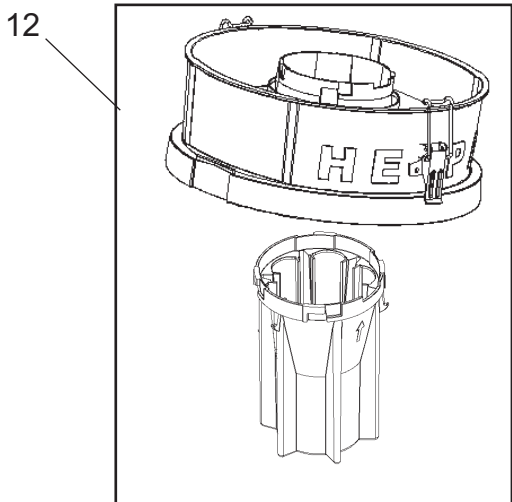
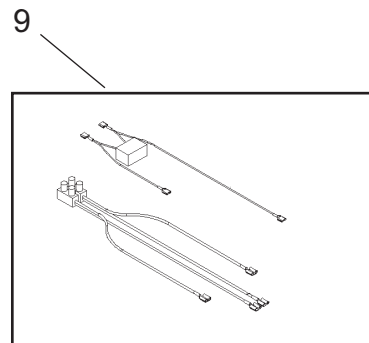
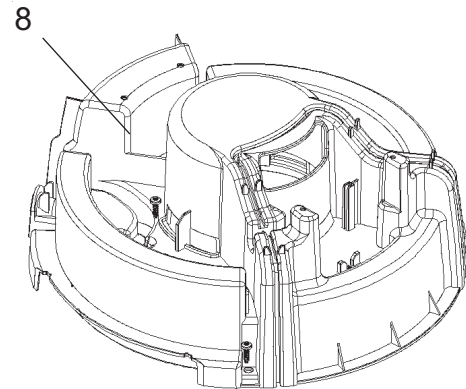
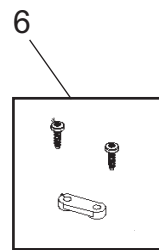
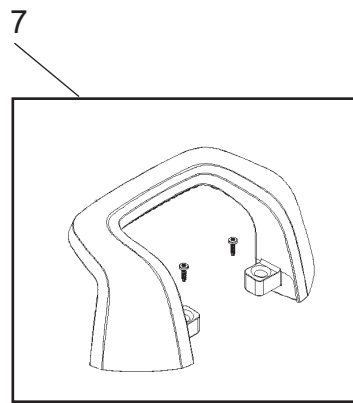
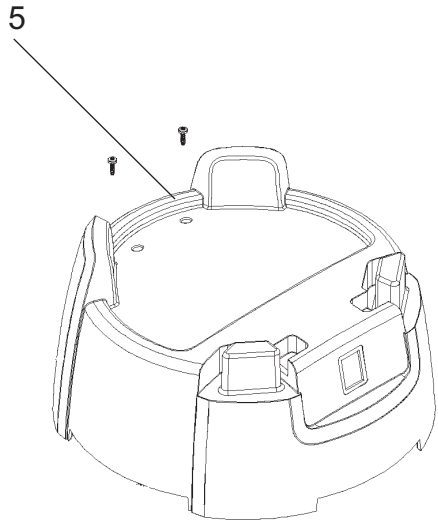
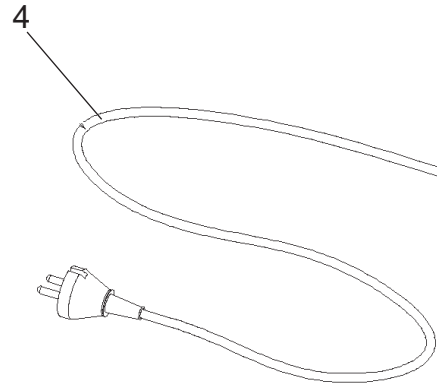
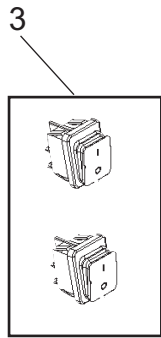
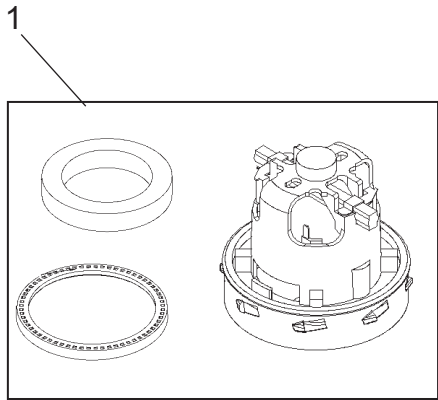

**04-11****MOTOR TOP****823 0078 020****ELIMINATOR I****3**

<b>Item.No.</b>	<b>Part No.</b>	<b>Qty.</b>	<b>Description</b>	<b>Note</b>
1	140 8689 510	1	Fan unit By-pass 100-120V	Gaskets included
3	140 9537 500	2	Switch two pole	
4	147 0716 500	1	Cord set grounded 50 feet (15,5 meters)	
5	140 8652 520	1	Cover outer, UL-approved	Screws included
6	140 6560 500	1	Anti strain clip	Screws included
7	140 8650 500	1	Handle	Screws incl.
8	140 8653 510	1	Cover fan unit, UL-approved	
9	140 7620 510	1	Internal wires, UL-approved	
10	140 8664 520	1	Chassis, UL-approved	
12	147 0751 500	1	Float chamber	For converting to a wet cleaner

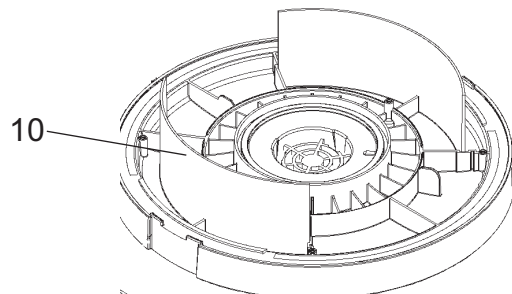
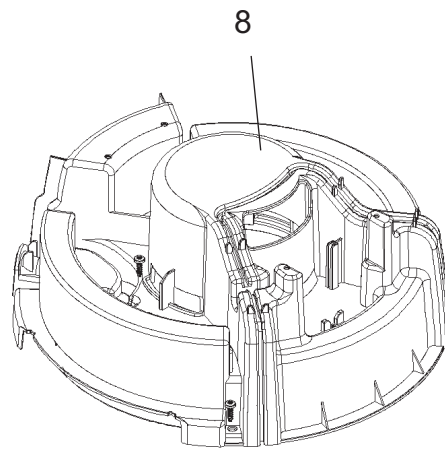
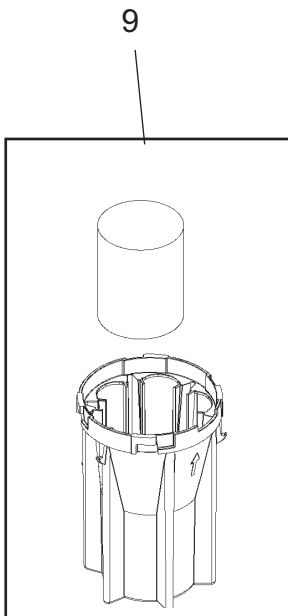
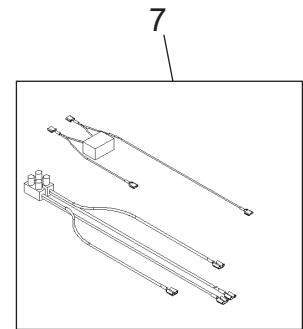
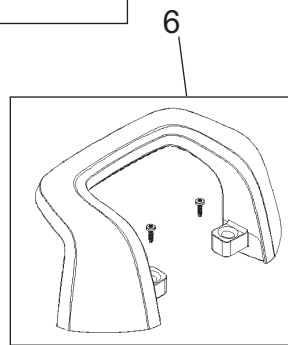
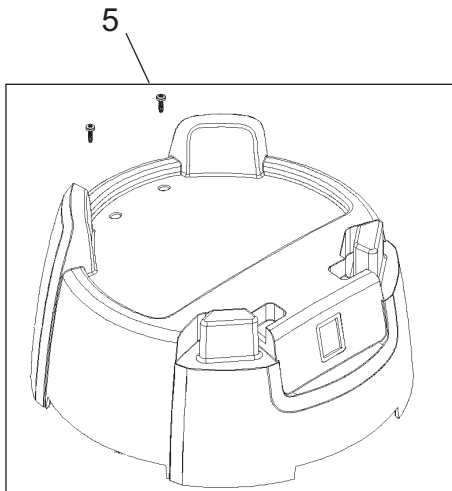
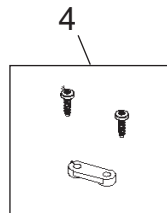
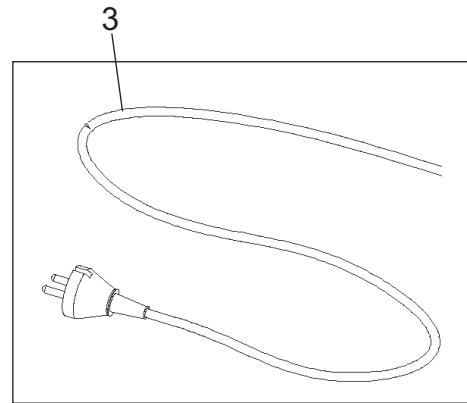
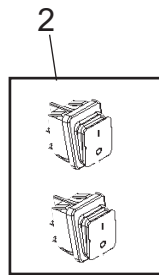
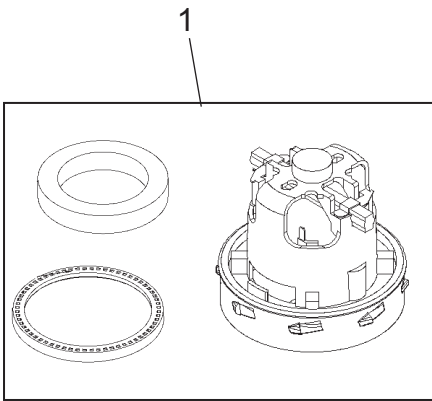

**04-11****MOTOR TOP****823 0078 020****ELIMINATOR II****5**

<b>Item.No.</b>	<b>Part No.</b>	<b>Qty.</b>	<b>Description</b>	<b>Note</b>
1	140 8689 510	1	Fan unit By-pass 100-120V	Gaskets included
2	140 9537 500	2	Switch two pole	
3	147 0716 500	1	Cord set grounded 50 feet (15,5 meters)	
4	140 6560 500	1	Anti strain clip	Screws included
5	140 8652 520	1	Cover outer, UL-approved	Screws included
6	140 8650 500	1	Handle	Screws included
7	140 7620 510	1	Internal wires, UL-approved	
8	140 8653 510	1	Cover fan unit, UL-approved	
9	140 8680 500	1	Float basket	
10	140 8664 520	1	Chassis, UL-approved	

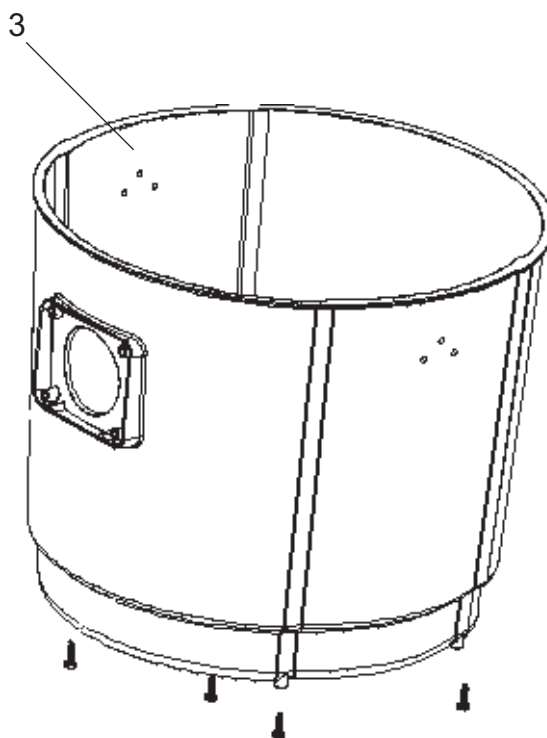
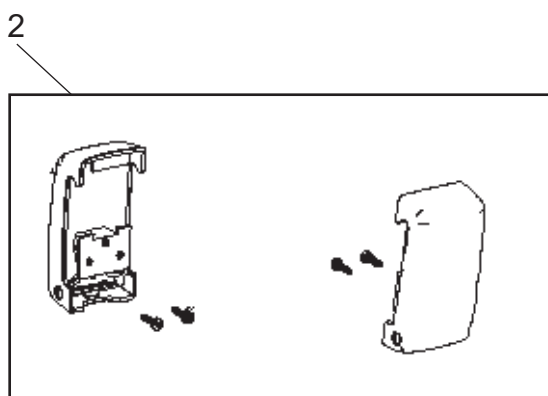
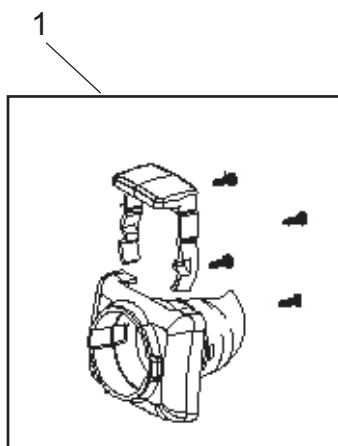

**04-11****CONTAINER****823 0078 020****ELIMINATOR I****7**

<b>Item.No.</b>	<b>Part No.</b>	<b>Qty.</b>	<b>Description</b>	<b>Note</b>
1	140 7204 500	1	Inlet	Screws and trigger included
2	140 8691 500	2	Latches 2-p.	Screws included
3	140 8660 500	1	Container 5 Gallon	Screws included

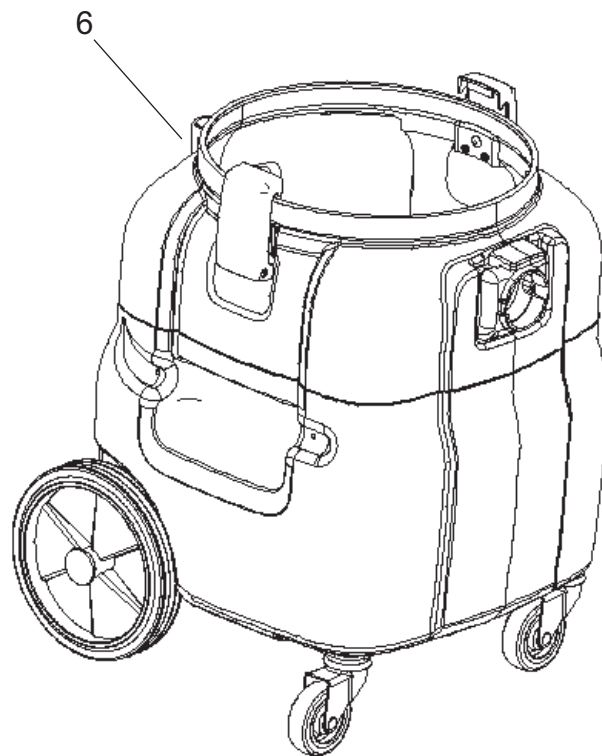
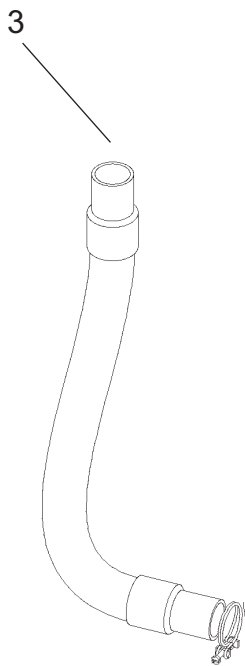
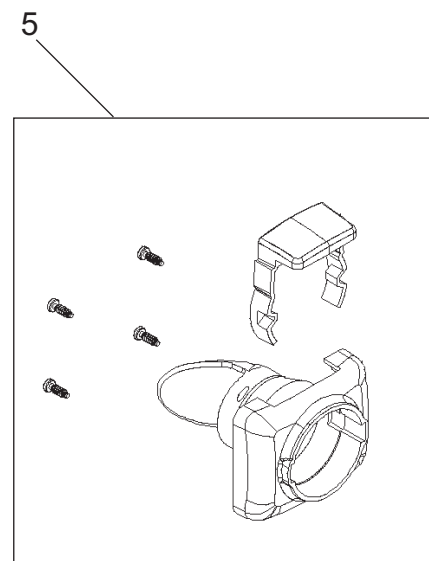
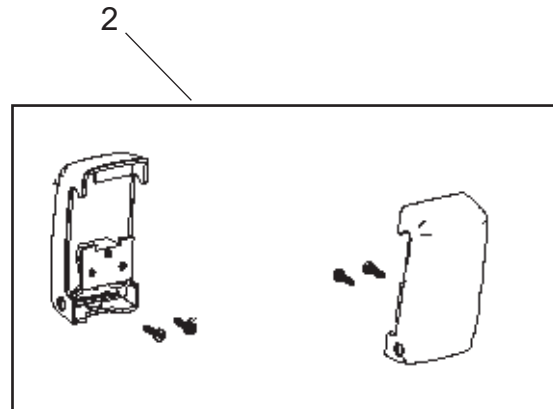
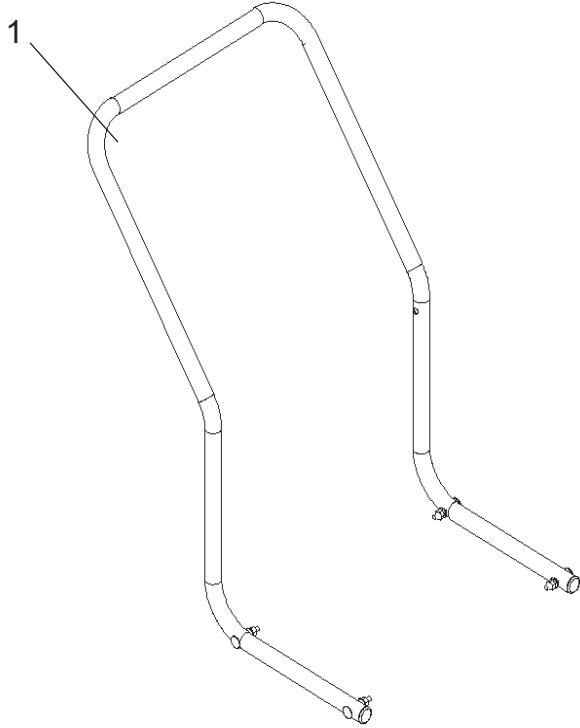

**04-11****CONTAINER AND HANDLE****823 0078 020****ELIMINATOR II****9**

<b>Item.No.</b>	<b>Part No.</b>	<b>Qty.</b>	<b>Description</b>	<b>Note</b>
1	147 0712 500	1	Handle cpl.	Screws included
2	140 8691 500	2	Latches	Screws included
3	140 7604 510	1	Drain hose	
5	140 7204 500	1	Inlet	Screws and trigger included
6	140 9554 500	1	Container 12 Gallon	Complete container with wheels

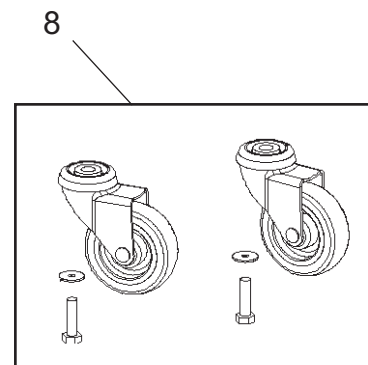
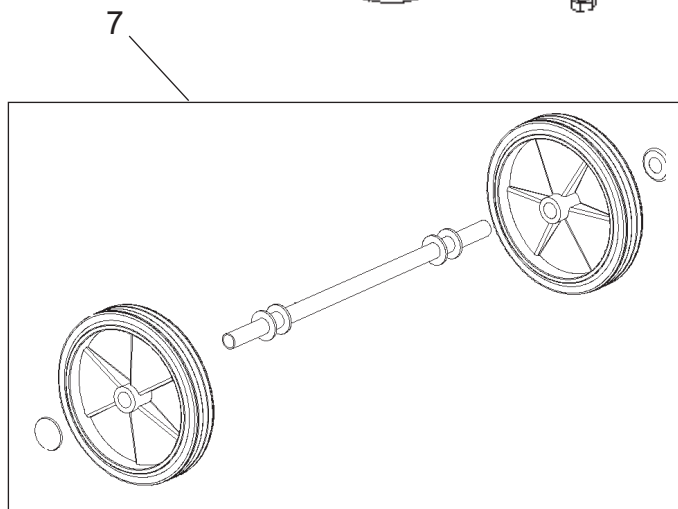
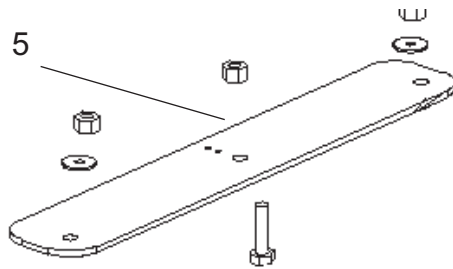
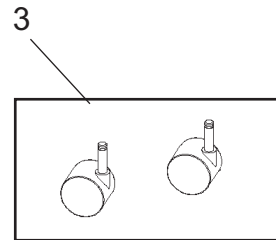
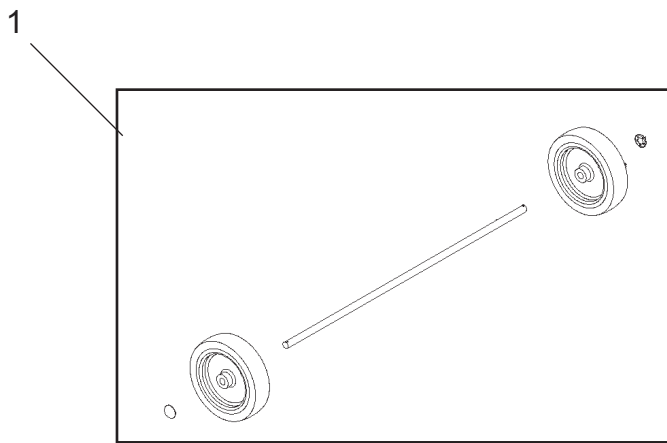
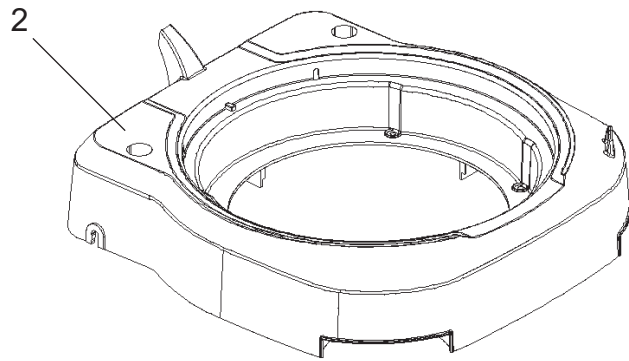

**04-11****WHEELS****823 0078 020****ELIMINATOR I, ELIMINATOR II****11**

<b>Item.No.</b>	<b>Part No.</b>	<b>Qty.</b>	<b>Description</b>	<b>Note</b>
<b>Eliminator I</b>				
1	140 8446 600	2	Wheels rear	2 wheels, shaft included
2	140 8662 500	1	Frame for trolley	
3	140 6422 500	2	Castor wheels Ø 2.0 in (50 mm) 2 wheels	
<b>Eliminator II</b>				
5	140 9553 500	1	Bracket plate for castor wheels	Screws and nuts included
7	140 9543 500	2	Wheels Ø 8.0 in (200 mm)	Shaft included
8	140 5476 520	2	Castor wheels	Screws and washers included

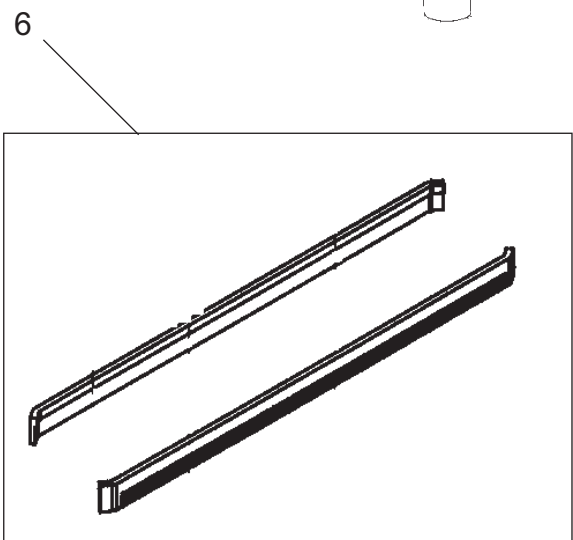
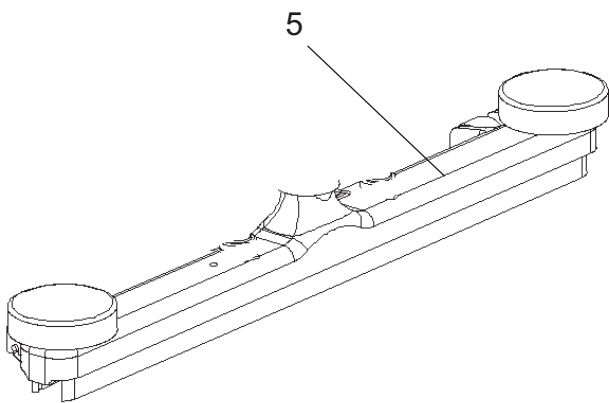
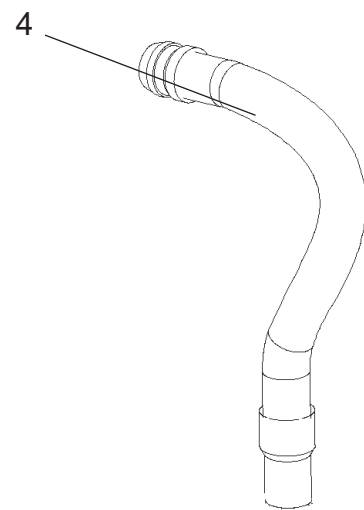
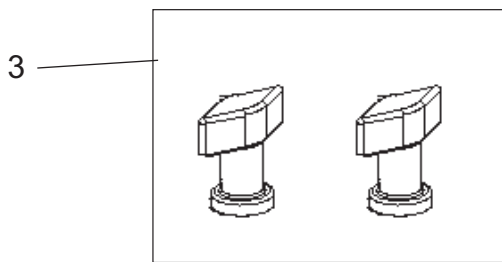
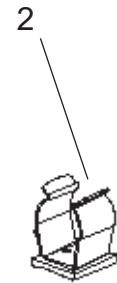
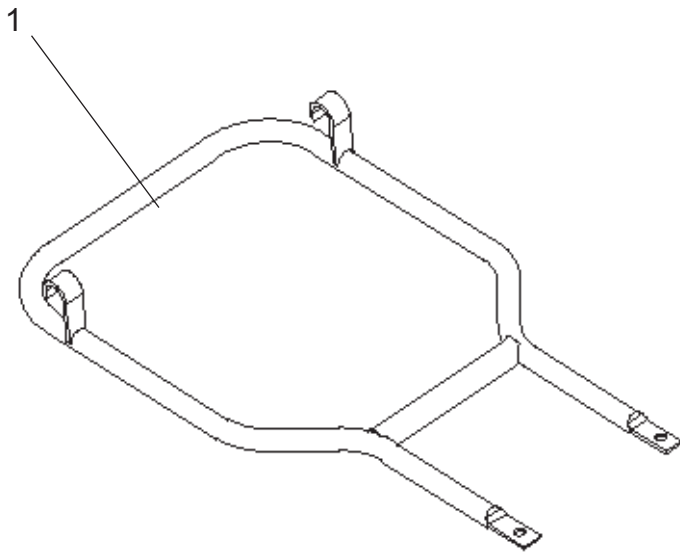

**04-11****FRONT NOZZLE****823 0078 020****ELIMINATOR II****13**

<b>No.</b>	<b>Part No.</b>	<b>Qty.</b>	<b>Description</b>
1	140 9547 500	1	Frame, front nozzle
2	140 9558 500	1	Clamp Ø 0.86 in
3	140 7947 500	2	Nut, thumb 5/16
4	140 2148 500	1	Hose, Ø 1.50 in 1 1/2 ", 500mm
5	56209088	1	Squeegee 24"
6	56105533	2	Blade, 24", 600 mm

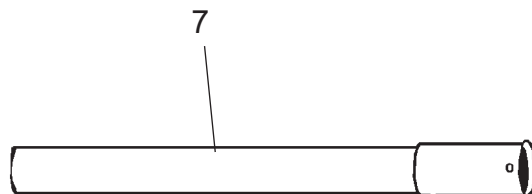
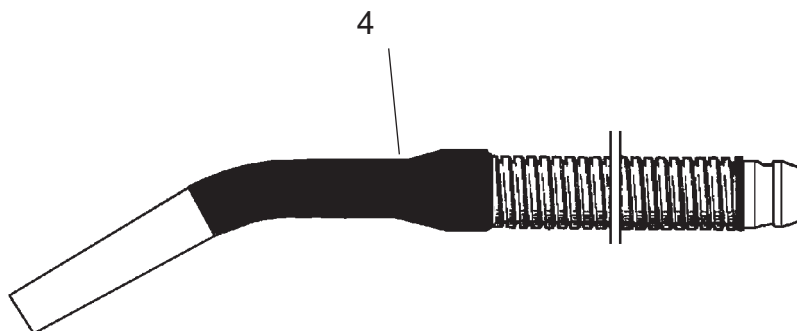
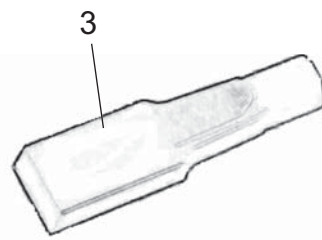
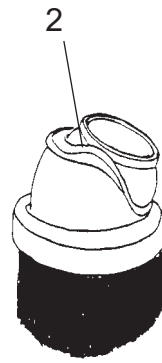
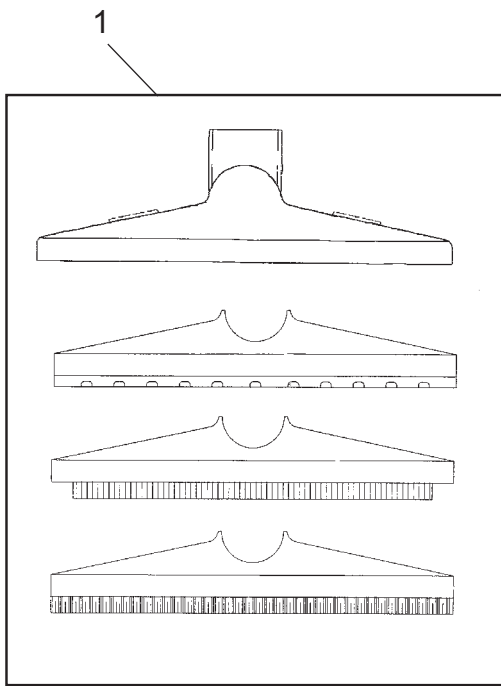

## ELIMINATOR I, ELIMINATOR II

Item.No.	Part No.	Qty.	Description	Note
1	140 8248 040	1	Universal nozzle, Ø 1.50 in	Complete with rubber strips, brush strips and carpet insert
2	010 7031 000	1	Brush nozzle	Adjustable
3	140 8258 000	1	Crevice nozzle Ø 1.50 in	Mat.: Plastic
4	140 4001 010	1	Hose complete with handle	Mat.: Plastic hose Ø 1.50 in Snap in coupling
7	011 6451 010	1	Extension tube Aluminium	Ø 1.50 in L= 19.68 in (500 mm)

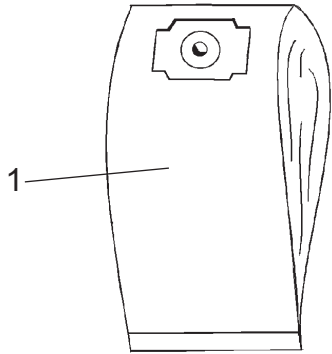

2

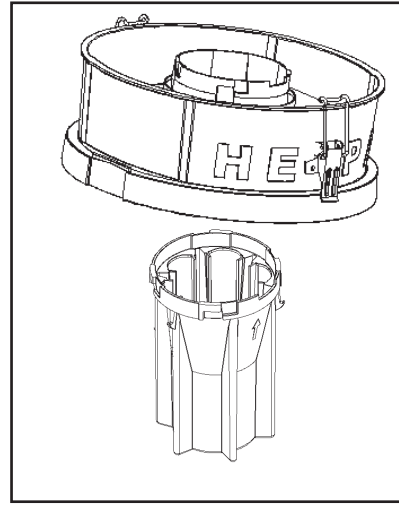

2B

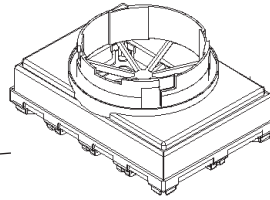

3

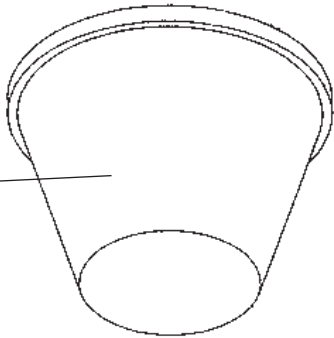

4

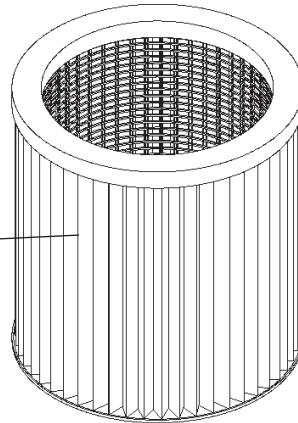

5



## ELIMINATOR I, ELIMINATOR II

<u>Item.No.</u>	<u>Part No.</u>	<u>Qty.</u>	<u>Description</u>	<u>Note</u>
1	147 0745 010	3	Dust bags,	For Eliminator I
1	147 0746 010	3	Dust bags,	For Eliminator II
2	147 0751 500	1	Float chamber	
2B	140 8678 500	1	Filter HEPA	
3	140 8658 500	1	Main filter	For all models
4	140 8686 500	1	Filter Cartridge	For all models
5	140 8682 500	1	Filter motor	For all models

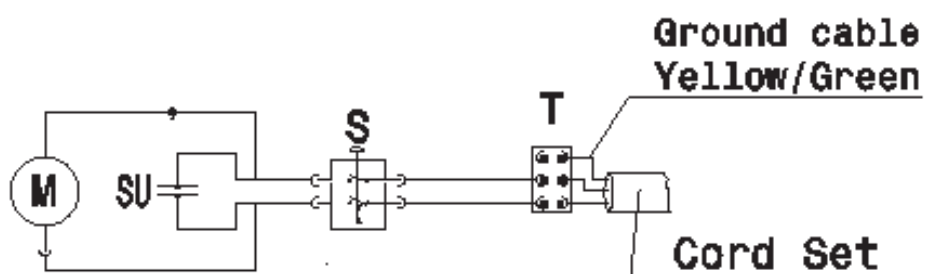

**M** Fan Unit

**S** Switch

**SU** Suppressor Unit

**T** Terminal Block